

# FLEXA®

81-24501-1/-2/-11/-81/-82/-85/-86/  
-87/-88/-91/-92/-96/-97/-98/-99

81-24510-1/-2/-11/-81/-82/-85/-86/  
-87/-88/-91/-92/-96/-97/-98/-99

72 x 135,5 x 34,5/35cm

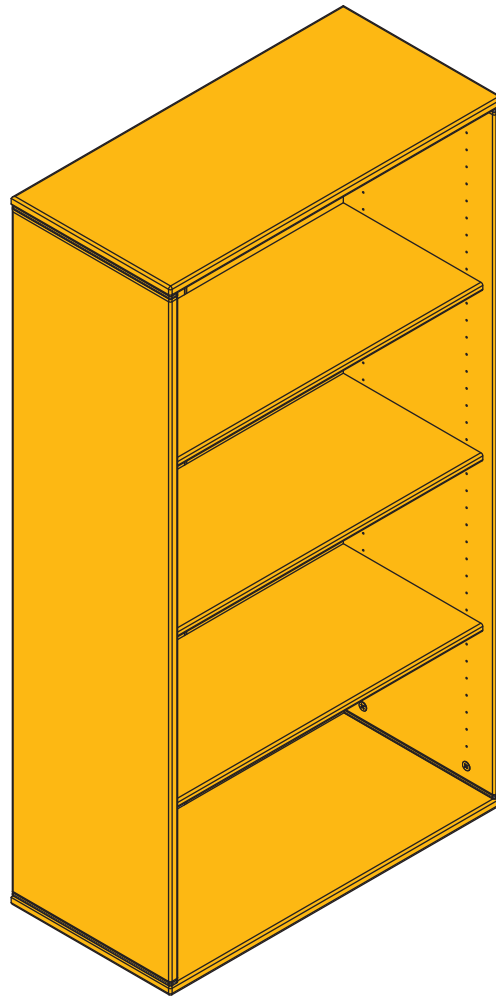

Monterings- og brugsvejledning  
Assembly instructions and direction for use  
Montageanleitung und Gebrauchsanweisung  
Notice de montage et mode d'emploi  
Montageinstructie en onderhouds voorschrift  
Instrucciones de montaje y uso  
Istruzioni di montaggio e uso  
Kokoamis- ja käyttöohjeet  
Οδηγίες συναρμολόγησης και χρήσης

Instrukcje montażu i wskazówki dotyczące użytkowania  
Instruções de montagem e de utilização  
Instrucțiunile de asamblare și recomandări de utilizare.  
Инструкции по сборке и руководство использования  
安裝及使用說明  
組立ておよび使用説明  
รายละเอียดเกี่ยวกับวิธีกาไรใช้  
และการติดตั้ง  
설치 및 취급설명

For indoor  
domestic use

Scandinavian Design made in Estonia



Møbler fra FLEXA er fremstillet af enten massivt træ eller højvællers MDF. Massivt træ kan have farve- og strukturskille, hvilket er en naturlig del af møbler, fordi det er et naturmateriale. Skulle der mod forventning opstå en reklamation, skal denne blankt udfyldes og returneres til FLEXA forhandleren. Venligst kontroller, at alle dele er komplette, inden montage påbegyndes.



Furniture from FLEXA is produced from solid wood or high quality MDF. Solid wood can have color and structure difference which is a natural part of the furniture. However should a complaint occur, this form must be filled and returned to your FLEXA stockist. Please make sure that all parts are complete before you start assembling.



Die FLEXA Produkte werden aus massivem Kiefernholz oder aus MDF von hoher Qualität hergestellt. Bei massivem Holz sind Farbunterschiede sowie unterschiedliche Maserungen Naturmerkmale. Sollte es trotzdem Grund zur Reklamation geben, füllen Sie bitte diesen Schein aus und wenden Sie sich an Ihren FLEXA Händler. Kontrollieren Sie vor Montagebeginn den Artikel auf Vollständigkeit und Beschädigungen.



Le mobilier FLEXA est réalisé en bois massif ou en MDF de haute qualité. La structure et la couleur peuvent présenter un léger écart, car c'est une matière naturelle. Si toutefois vous constatez une anomalie, merci de remplir le fiche ci-jointe et de la retourner à votre revendeur. Veuillez vérifier l'intégralité des pièces avant d'entreprendre le montage.



Los muebles de FLEXA son fabricados con madera maciza o MDF de alta calidad. La madera maciza puede tener diferencias de color y estructura, esto es una parte natural de los muebles. Si en contra de lo previsto surge una incidencia, hay que rellenar este formulario y devolverlo al distribuidor. Los registros controlen que todas las piezas están completas antes de empezar el montaje.



Modeli van FLEXA zijn vervaardigd uit hard of hoog kwaliteits MDF. Bij massief hout kunnen kleur- en structuurverschillen voorkomen, wat een natuurlijk kenmerk is van het meubilair. Mocht er desondanks een klacht ontstaan, vul dan dit formulier in en lever het in bij uw FLEXA dealer. Controleer of alle benodigde onderdelen aanwezig zijn voordat u begint met monteren.



I mobili FLEXA sono prodotti in legno massello o MDF di alta qualità. Il legno massello può avere alcune differenze di colore, o di consistenza, il che è normale per un materiale naturale. Comunque per qualsiasi reclamo bisogna riempire il modulo e consegnarlo al Vostro rivenditore. Vi preghiamo di controllare che tutti i pezzi siano intatti prima di cominciare il montaggio.



Model nr. / Model No / Modell Nr. /  
Modelo no / No Modelo / Artikel nr. /  
Numero Modello

Emne nr. / Part / Teile-Nr. /  
Piece réclamée / No. pieza /  
Onderdeelnnummer / No. pezzo

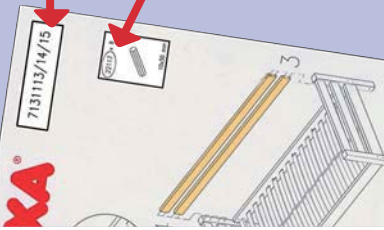

Årsag

Reason

Ursache

Motif

Motivo

Oorzaak

Motivo

1 Manglende del / Missing part /  
Fehlendes Teil / Pièce manquante /  
Falta pieza / Missende delen / Parte  
mancante

2 Fejl i træet / Defect in the wood /  
Holzfehler / Défaut de bois /  
Madera defectuosa / Fout in het  
hout / Difetto nel legno

3 Fejlboring / Faulty drilling  
Falsche Bohrung / Défaut de  
percage  
Taladro erróneo / Verkeerd geboord  
Difetto forature

4 Fejl i lakken / Fault in lacquer  
Fehler im Lack / Défaut de finition  
Barniz defecto / Fout in de  
lakafwerking / Difetto laccatura



Møbler fra FLEXA er fremstillet af enten massivt træ, hvilket betyder at farve- og strukturskille, hvilket er en naturlig del af møbler, fordi det er et naturmateriale. Skulle der mod forventning opstå en reklamation, skal denne blankt udfyldes og returneres til FLEXA forhandleren. Venligst kontroller, at alle dele er komplette, inden montage påbegyndes.



Furniture from FLEXA is produced from solid wood, which means that color and structure difference are a natural part of the furniture. However should a complaint occur, this form must be filled and returned to your authorized FLEXA dealer. Please make sure that all parts are complete before you start assembling.



FLEXA家具由实木制成。存在实木的自然色和纹理的差异。若发现产品有质量问题，请填写右侧的表格，返还给FLEXA授权经销商。安装前请按照包装清单仔细核对。



FLEXA家具由实木制成。存在实木的自然色和纹理的差异。若发现产品有质量问题，请填写右侧的表格，返还给FLEXA授权经销商。安装前请按照包装清单仔细核对。



FLEXA家具は本製家具として木の自然の色と模様があり、製品に品質問題があれは、右の表をご記入の上、FLEXAの取扱代理店にご返送下さい。組立ての前にはパッケージとご確認ください。



FLEXA 가구는 원목과 제프로 제작되어 원목 특유의 자연 색채와 무늬가 있습니다. 품질상의 문제가 발견될 경우 오른쪽 표에 그 내용을 기재하여 FLEXA의 공식 판매처에 보내주시요. 설치 전 포장리스트와 포장내용물의 확인 하십시오.



เฟอร์นิเจอร์ FLEXA เป็นผลิตภัณฑ์ที่ทำมาจากไม้จริงและมีความทนทานสูงซึ่งเป็นเรื่องที่ควรคำนึงถึงก่อนการใช้งานเฟอร์นิเจอร์ไม้ประเภทนี้ การพบข้อบกพร่องใดๆ กรุณาตรวจสอบกล่องก่อนจะนำออกมา และส่งคืนให้ตัวแทนผู้จำหน่ายของคุณก่อนจะเริ่มขั้นตอนการประกอบเฟอร์นิเจอร์

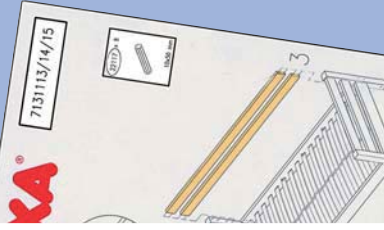

Model nr. / Model No / 产品编号 /  
產品編號 / 製品ナンバー / 제품번호 /  
หมายเลขสินค้า

Emne nr. / Part / 配件号 /  
配件號 / パーツナンバー / 부품번호 /  
หมายเลขชิ้นส่วนของโต๊ะ

Årsag

Reason

原因

原因

原因は

이유

การณ

1 Manglende del / Missing part /  
配件缺失 / 配件缺失 / パーツ欠け /  
빠진 부품 / ชิ้นส่วนของโต๊ะขาดหาย

2 Fejl i træet / Defect in the wood /  
木材缺陷 / 木材缺陷 /  
材木欠陥 / 목재 손상 /  
คุณภาพของเนื้อไม้ไม่ได้มาตรฐาน

3 Fejlboring / Faulty drilling /  
钻孔错误 / 鑽孔錯誤 / 穴空けミス /  
드릴링 착오 /เจาะรูผิดพลาด

4 Fejl i lakken / Fault in lacquer /  
油漆问题 / 油漆問題 / 塗装問題 /  
라커 문제 / วัสดุสีไม้ไม่เคลือบเงาไม่  
ได้ตามมาตรฐาน



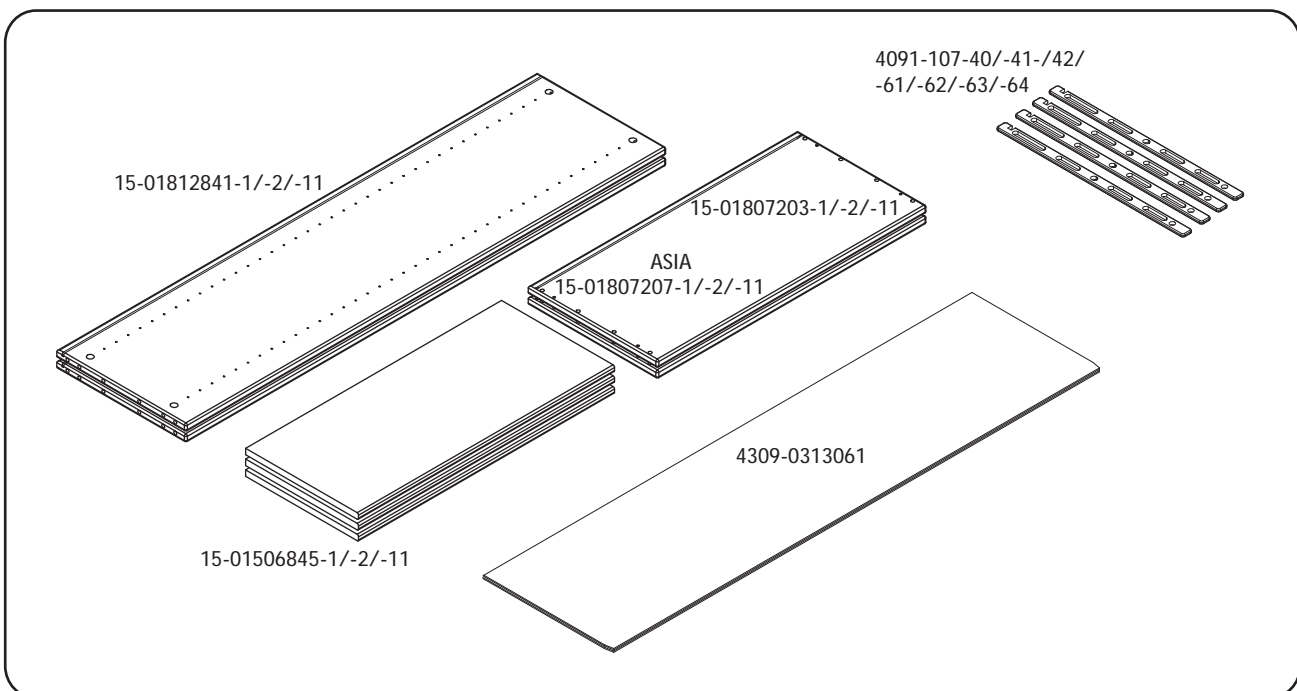
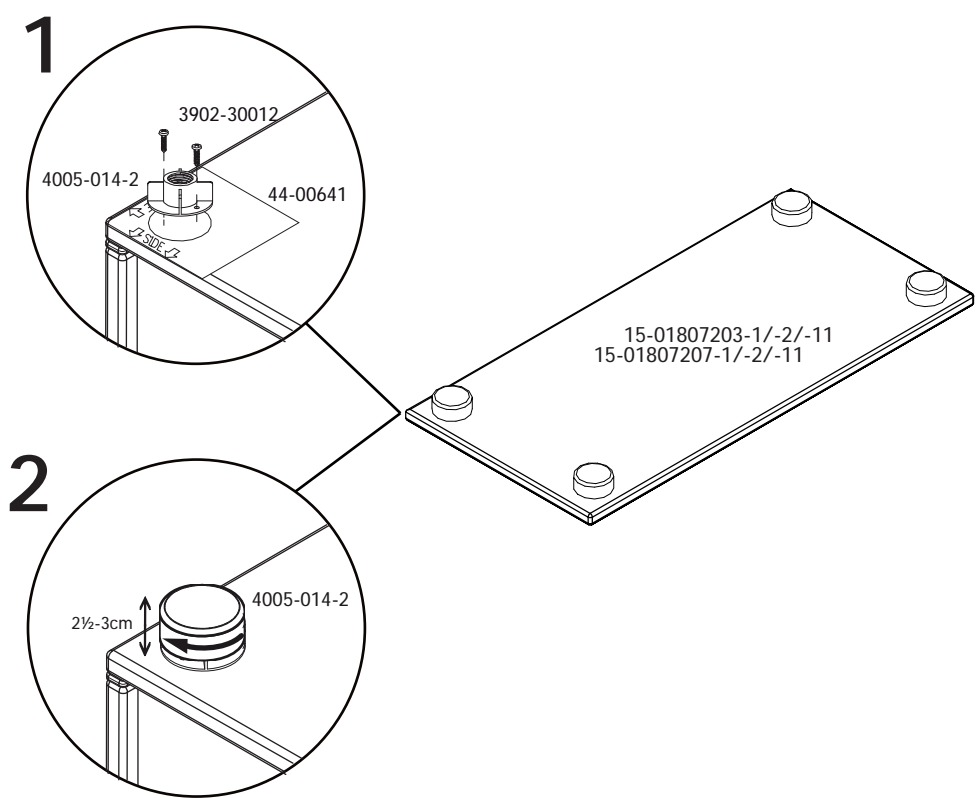
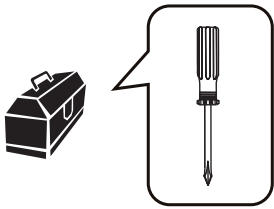
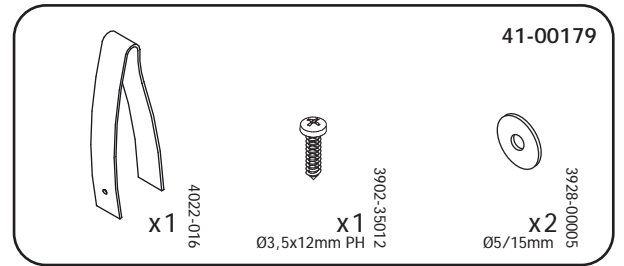
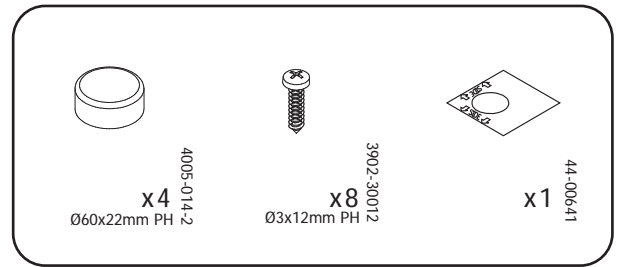
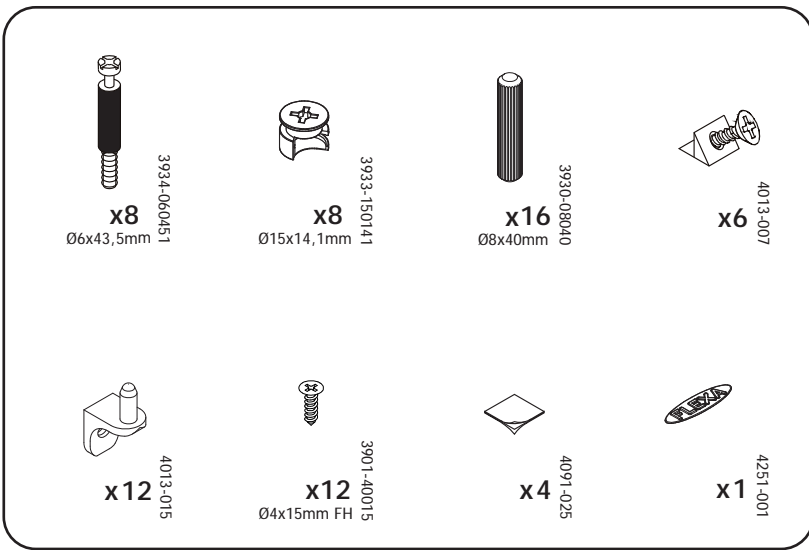

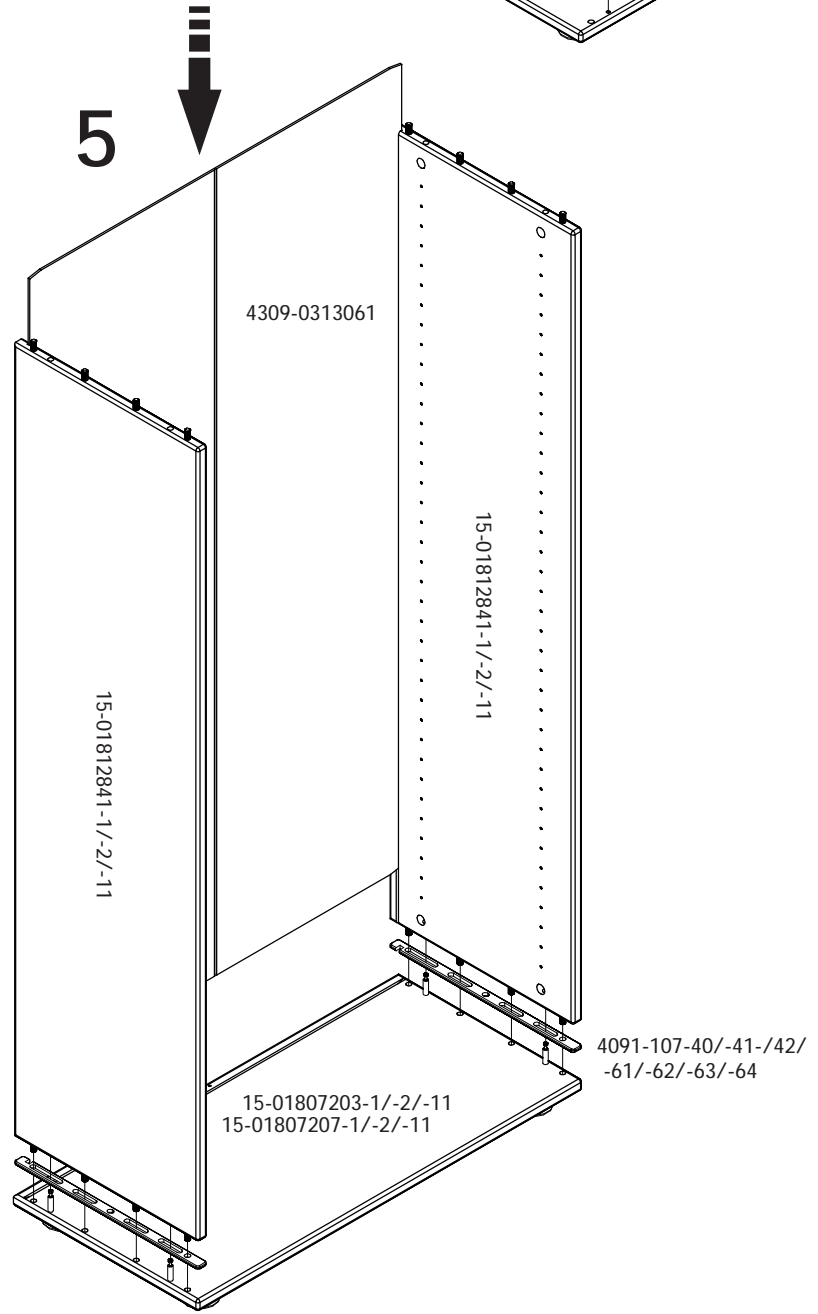
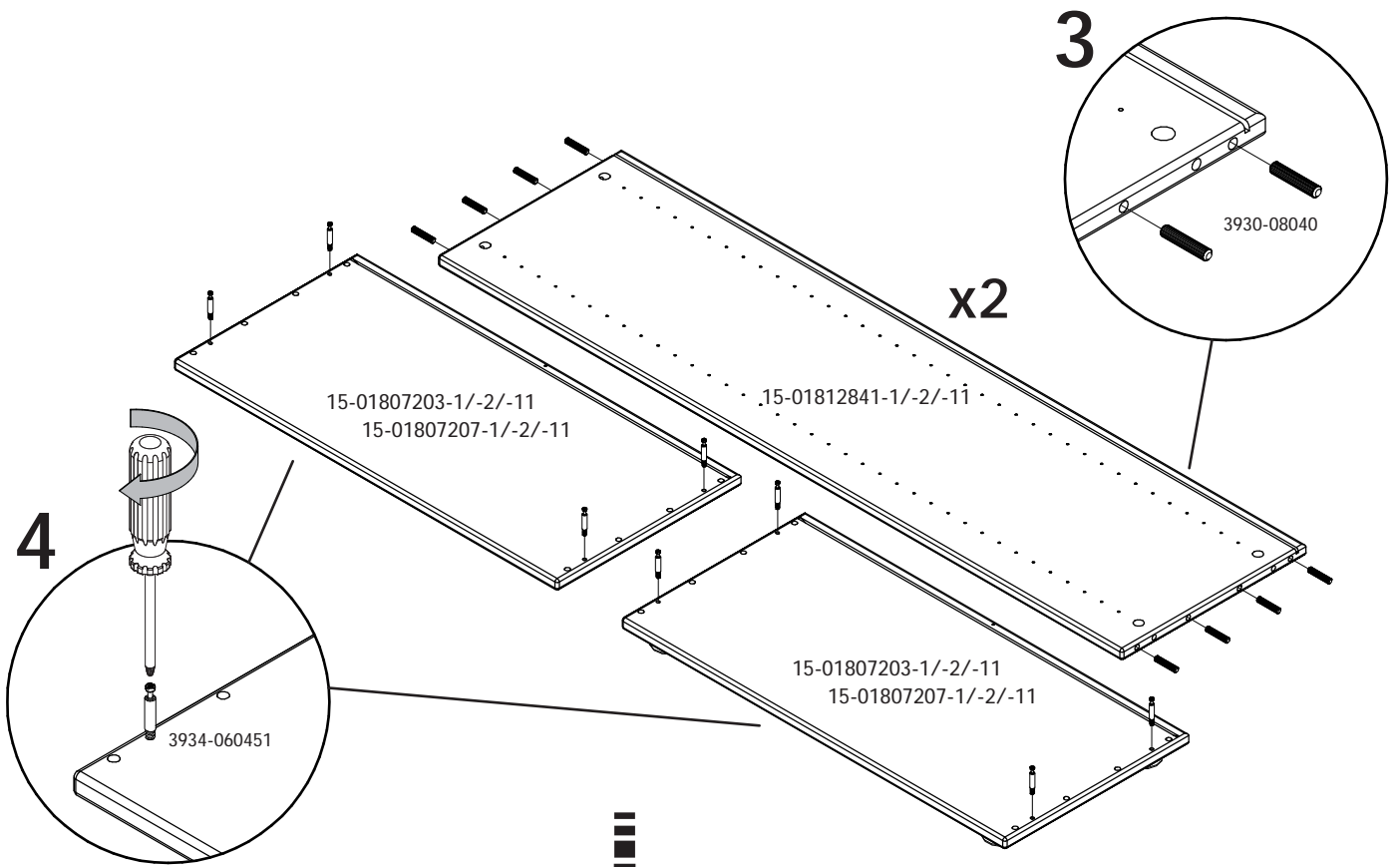

4091-107-40/-41-/42/  
-61/-62/-63/-64

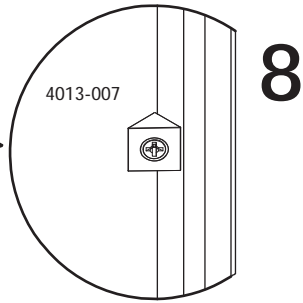
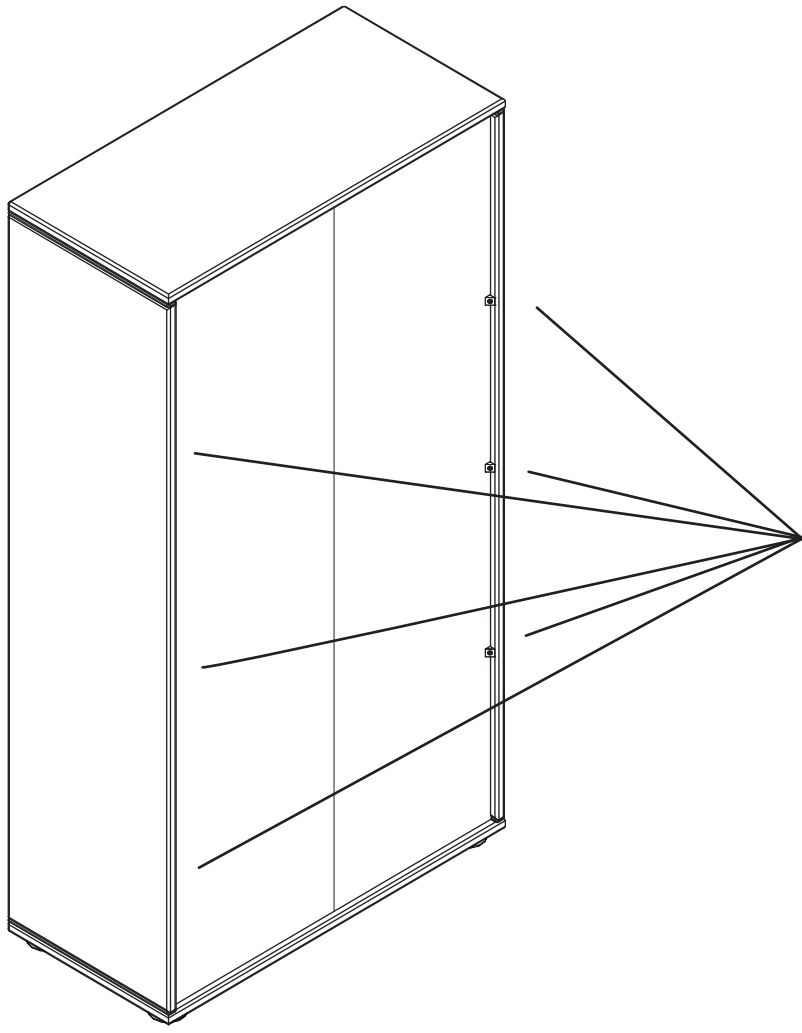
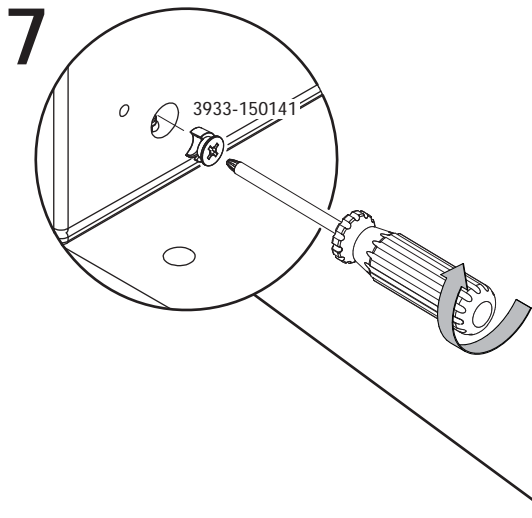
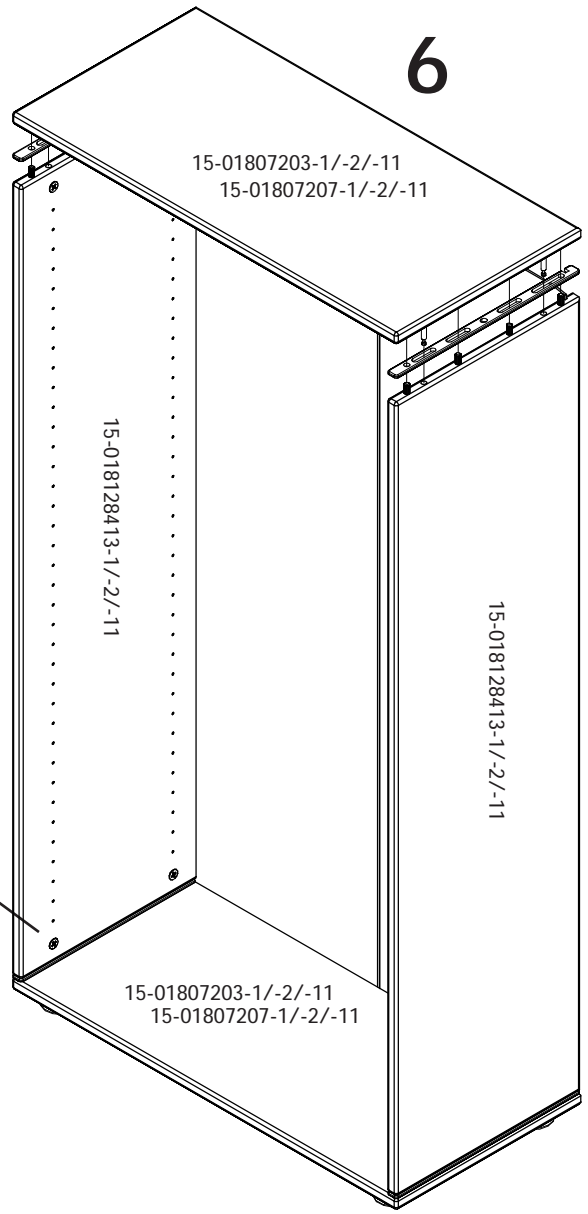

8

9

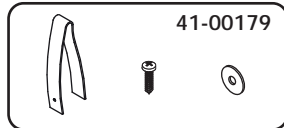

10

15-01506845-1/-2/-11

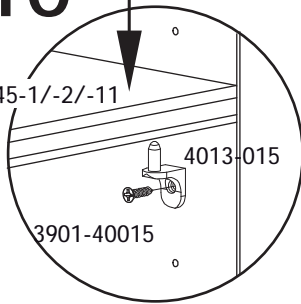

4013-015

3901-40015

11

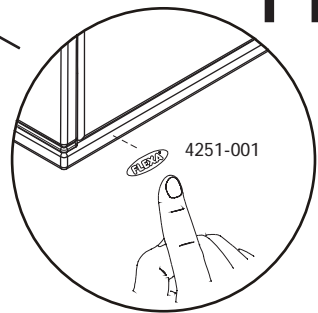

4251-001

4091-025

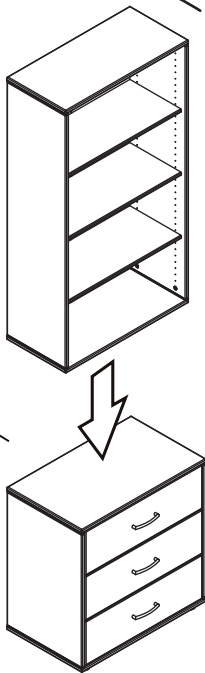
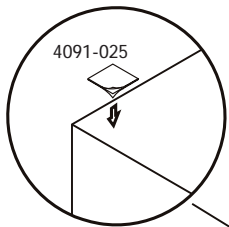
**RÅD OM VEDLIGEHOLDELSE:**

Tør af med en fugtig klud. Evt. større pletter fjernes større pletter fjernes med en fugtig svamp med sæbe. Undgå opløsningsmidler. Skruer og bolte efterspændes med jævne mellemrum.

**CONSEILS D'ENTRETIEN:**

Entretien avec un chiffon humide pour la poussière - les tâches rebelles s'enlèvent avec une éponge légèrement une éponge légèrement savonneuse. Eviter tous solvants et diluants. Votre lit doit être vérifié périodiquement afin de resserrer les vis.

**CONSIGLI PER LA MANUTENZIONE:**

Pulire con un pannoumido, usare una spugna impregnata spugna impregnata di sapone per togliere lo sporco persistente. Evitare l'uso de prodotti chimici. Dadi e viti sono, di Dadi e viti sono, di tanto e tanto, da ri-avvitare.

**MAINTENANCE INSTRUCTIONS:**

Cleaning with a wet cloth, use a sponge with soap to remove obstinate dirt. Avoid solvents and dilutions. Screws and bolts should from time to time be retightened.

**CONSEJO PARA LA CONSERVACIÓN:**

Limpiar con un paño húmedo. Para quitar manchas mas grandes usar mas grandes usar una esponja conuna esponja con jabón. Evitar usar productos quimicos. Las herrajes necesitan opretarse a veces

**保养说明:**

用湿布擦拭, 用海绵蘸上肥皂来除去顽固性污垢。避免使用溶剂和稀释剂。应经常重新固定螺钉和螺栓。

**PFLEGEHINWEIS:**

Pflege mit einem feuchten Lappen. Für hartnäckigen Schmutz empfehlen wir einen Schwamm mit Seife. Vermeiden Sie Lösungs- und Verdünnungsmittel. Schrauben und Bolzen sollten regelmässig nachgezogen werden.

**ONDERHOUD:**

Reinigen met een vochtige doek. Hardnekkig vuil verwijderen met een spons en zeep. Vermijd oplos- en verdunningsmiddelen. Schroeven en moeren regelmatig aandraaien.

**メンテナンス説明:**

汚れた場合は濡れ雑巾で拭き取って下さい。ひどい汚れの場合は石鹸をつけたスポンジで拭き取って下さい。溶剤、シンナーは使用しないでください。ネジ等金具は時々締め直して下さい。



## Product Declaration

**Product:** Children's furniture

**Product No:** Please refer to the label or the Assembly and User Instruction. The product code refers to the type, length and color of the product. As an example the item number 80-01101-1, a basic bed, 80-01101 - 190cm long, 80-01101-1-clear lacquered. 80-01102-2, a basic bed, 80-01102 - 200cm long, 80-01102-2 · white lacquered.

**Technical character and size:** Please refer to the Assembly and User Instruction.

**Main material:** Northern European Pinewood, harvested above the 60<sup>th</sup> latitude  
**Lacquer:** Water soluble UV lacquer complying with the EN standard  
**Glue:** Urea glue complying with the EN standard  
**Metal parts:** Coating complying with the EN71 standard, part 3

**Production date:** Please refer to the label on the outer package.

Furniture products from FLEXA® are tested according to relevant European and American safety standards, e. g. EN, CE, GS, and CFR. Furthermore, FLEXA's products are test by the China National Quality Supervision Center for Furniture and complying with the GB28007-2011 children furniture standard in China and other relevant standards. Also, we comply with the EN717 concern the formaldehyde release.

**Assembly and spare parts:** Please refer to the Assembly and User Instruction.

**Maintenance:** Please refer to the Assembly and User Instruction.



**Safety tested** FLEXA furniture is made for children. We have carefully checked every single detail so you can safely set up your child's bedroom. For example, there are no sharp edges or corners on FLEXA furniture - they are all rounded. All beds with a sleeping height of more than 80 cm are safety tested according to the EU standard EN:747 by TÜV.



**5-year guarantee** FLEXA's aim is always to deliver the highest quality and safety. That is why we provide a 5-year guarantee against manufacturing defects on all our furniture. The guarantee does not cover damage to the lacquer surface caused by knocks or wear and tear.



**5-year availability guarantee** When you purchase FLEXA, you buy a flexible system that can be altered and extended as and when the need arises. The FLEXA availability guarantee means that you can buy new modules for your bed for at least five years after you purchased the first unit.



**Quality materials** FLEXA insists on the highest quality and sustainability as a standard when we make furniture. For example, we only use the highest quality pine from sustainable forests in Scandinavian. We are thereby ensuring that only the very best material is used for our furniture.



**Lacquer** FLEXA furniture is surface treated with lacquer several times to give our furniture an optimal and elegant finish. At the same time it makes our furniture robust and more resistant to signs of wear and tear. FLEXA is only using eco-friendly water-based lacquer and UV lacquer, which meets the EU standard for lacquer.



**Colour differences** Many FLEXA furniture is made of solid wood or part of it is in solid wood and natural differences in colour may appear between individual products. This is only natural since wood is a living product. All FLEXA textiles are 100% natural products. Natural differences in colour may occur.

Children's furniture from the Danish company, FLEXA, is designed by FLEXA according to Scandinavian design traditions. The wood furniture are manufactured by FLEXA in Europe and sold worldwide.

FLEXA® and the FLEXA® logo are trademarks of Flexa4Dreams Holding A/S.

For 3 years old or above.  
Only for adult to assemble.

Manufacturer: FLEXA4Dreams Holding A/S, Denmark  
Address: Hornsyld Industrivej 4, 8783 Hornsyld, Denmark  
Tel: +45 7668 8055 Fax: +45 7668 8069  
Email: flexa@flexa.dk  
Website: www.flexa.dk

## 产品说明书

产 品 品 类：儿童家具

产 品 编 号：参见标签或包装内的安装及使用说明。产品编号代表产品的类型、长度和颜色。例如：80-01101-1，为基本床，80-01101-190cm，80-01101-1-本色。80-01102-1，为基本床。80-01102-200cm，80-01102-2-白色。

技术特征和尺寸：见安装及使用说明。

主 料：北纬60度以上的北欧松木。

油 漆：水溶性UV漆，符合EN标准。

胶 水：水溶性粘合剂，符合EN标准。

金 属 配 件：镀层符合欧洲玩具安全标准EN71，第三部分。

芙莱莎集团出品的家具经过欧洲和美国最严格的安全测试，符合EN, CE, GS, CFR 标准，芙莱莎的产品经过国家家具质量监督检验中心的检测，符合儿童家具通用技术条件GB28007-2011——目前国内唯一的儿童家具国家强制标准和其他相关国家标准。同时我们符合欧洲标准EN717中针对甲醛释放量的要求。

安 装 及 配 送：见安装及使用说明。

日 常 维 护 保 养：见安装及使用说明。



**安全保证** 芙莱莎专为儿童制造，我们专注于每一个细节，以确保您可以安心布置儿童房，例如，芙莱莎儿童家具全无尖锐的边和角，所有边角都作磨圆处理；所有高度超过80厘米的床都要经过德国莱茵的高层床检测标准EN:747



**五年质保** 芙莱莎的目标是提供始终如一的高品质和安全性，因此芙莱莎推出5年质保服务，但仅针对家具生产制造过程中造成的缺陷，不针对漆面的损伤。



**五年附加保证** 一旦您购买了芙莱莎，您就购买了一套灵活多变的家具体系，您可以根据您不断变化的需求来重新改装您的芙莱莎家具，这就是芙莱莎五年附加质保服务，即在您购买第一套芙莱莎床品的五年内，您可以根据您的需求添置新的部件，组装成满足您需求的新的床品。



**高品质的木材** 芙莱莎始终如一的坚持最高品质，例如，我们只选用北纬斯堪地纳维亚森林中最优质的松木制作儿童家具。



**掉漆** 芙莱莎儿童家具的表面都用水性UV漆涂刷好几遍，以确保家具的最佳呈现，同时，可以让家具更加耐磨耐损。芙莱莎所使用的水性UV漆达到EU标准。



**自然色差异** 芙莱莎家具由纯松木制成，由于实木具有活性，因此会存在天然的色差，所有芙莱莎纺织品也由100%天然材料制成，因此也会存在色差

芙莱莎儿童家具产自丹麦，依照斯堪的纳维亚风格所设计。芙莱莎实木家具均由欧洲生产，然后发往全球销售。

芙莱莎® 和 FLEXA® 是 Flexa4Dreams Holding A/S (芙莱莎) 集团的注册商标。

适用于3岁以上年龄  
只允许成人安装，儿童勿近

生产商: FLEXA4Dreams Holding A/S, Denmark  
地 址: Hornsyld Industrivej 4, 8783 Hornsyld, Denmark  
电 话: +45 7668 8055 传真: +45 7668 8069  
邮 箱: flexa@flexa.dk  
网 址: www.flexa.dk